



+3.3V/+5V, 8-Channel Relay Drivers with Fast Recovery Time and Power-Save Mode

MAX4822-MAX4825

General Description

The MAX4822-MAX4825 8-channel relay drivers offer built-in kickback protection and drive +3V/+5V non-latching or dual-coil-latching relays. Each independent open-drain output features a 2.7Ω (typ) on-resistance and is guaranteed to sink 70mA (min) of load current. These devices consume less than 300μA (max) quiescent current and have 1μA output off-leakage current. A Zener-kickback-protection circuit significantly reduces recovery time in applications where switching speed is critical.

The MAX4822/MAX4824 feature a unique power-save mode where the relay current, after activation, can be reduced to a level just above the relay hold-current threshold. This mode keeps the relay activated while significantly reducing the power consumption.

The MAX4822/MAX4823 feature a 10MHz SPI™-/QSPI™-/MICROWIRE™-compatible serial interface. Input data is shifted into a shift register and latched to the outputs when CS transitions from low to high. Each data bit in the shift register corresponds to a specific output, allowing independent control of all outputs.

The MAX4824/MAX4825 feature a 4-bit parallel-input interface. The first 3 bits (A0, A1, A2) determine the output address, and the fourth bit (LVL) determines whether the selected output is switched on or off. Data is latched to the outputs when CS transitions from low to high.

The MAX4822-MAX4825 feature separate set and reset functions, allowing turn-on or turn-off of all outputs simultaneously with a single control line. Built-in hysteresis (Schmidt trigger) on all digital inputs allows these devices to be used with slow-rising and falling signals, such as those from optocouplers or RC power-up initialization circuits. The MAX4822-MAX4825 are available in space-saving 4mm x 4mm, 20-pin thin QFN packages. They are specified over the -40°C to +85°C extended temperature range.

Applications

ATE Equipment
 DSL Redundancy Protection (ADSL/VDSL/HDSL)
 T1/E1 Redundancy Protection
 T3/E3 Redundancy Protection
 Industrial Equipment
 Test Equipment (Oscilloscopes, Spectrum Analyzers)

SPI is a trademark of Motorola, Inc.

QSPI is a trademark of Motorola, Inc.

MICROWIRE is a trademark of National Semiconductor Corp.



Maxim Integrated Products 1

Features

- ◆ Built-In Zener Kickback Protection for Fast Recovery
- ◆ Programmable Power-Save Mode Reduces Relay Power Consumption (MAX4822/MAX4824)
- ◆ 10MHz SPI-/QSPI-/MICROWIRE-Compatible Serial Interface
- ◆ Eight Independent Output Channels
- ◆ Drive +3V and +5V Relays
- ◆ Guaranteed 70mA (min) Coil Drive Current
- ◆ Guaranteed 5Ω (max) RON
- ◆ SET / RESET Functions to Turn On/Off All Outputs Simultaneously
- ◆ Serial Digital Output for Daisy Chaining
- ◆ Optional Parallel Interface (MAX4824/MAX4825)
- ◆ Low 300μA (max) Quiescent Supply Current
- ◆ Space-Saving, 4mm x 4mm, 20-Pin TQFN Package

Ordering Information

PART	TEMP RANGE	PIN-PACKAGE	PACKAGE CODE
MAX4822ETP	-40°C to +85°C	20 TQFN-EP*	T2044-3
MAX4823ETP	-40°C to +85°C	20 TQFN-EP*	T2044-3
MAX4824ETP	-40°C to +85°C	20 TQFN-EP*	T2044-3
MAX4825ETP	-40°C to +85°C	20 TQFN-EP*	T2044-3

*For maximum heat dissipation, packages have an exposed pad (EP) on the bottom. Solder exposed pad to GND.

Selector Guide

PART	INTERFACE	POWER SAVE
MAX4822	Serial	Yes
MAX4823	Serial	No
MAX4824	Parallel	Yes
MAX4825	Parallel	No

Pin Configurations appear at end of data sheet.

For pricing, delivery, and ordering information, please contact Maxim/Dallas Direct! at 1-888-629-4642, or visit Maxim's website at www.maxim-ic.com.

+3.3V/+5V, 8-Channel Relay Drivers with Fast Recovery Time and Power-Save Mode

ABSOLUTE MAXIMUM RATINGS

V _{CC}	-0.3V to +6.0V
OUT ₋	-0.3V to +11V
\overline{CS} , SCLK, DIN, SET, RESET, A0, A1, A2, LVL.....	-0.3V to +6.0V
DOUT.....	-0.3V to (V _{CC} + 0.3V)
PSAVE.....	-0.3V to (V _{CC} + 0.3V)
Continuous OUT ₋ Current (all outputs turned on).....	150mA
Continuous OUT ₋ Current (single output turned on).....	300mA

Continuous Power Dissipation (T _A = +70°C)	20-Lead Thin QFN (derate 16.9mW/°C above +70°C) ..1350mW
Operating Temperature Range	-40°C to +85°C
Junction Temperature	+150°C
Storage Temperature Range	-65°C to +150°C
Soldering Temperature (10s).....	+300°C

Stresses beyond those listed under "Absolute Maximum Ratings" may cause permanent damage to the device. These are stress ratings only, and functional operation of the device at these or any other conditions beyond those indicated in the operational sections of the specifications is not implied. Exposure to absolute maximum rating conditions for extended periods may affect device reliability.

ELECTRICAL CHARACTERISTICS

(V_{CC} = +2.7V to +5.5V, T_A = -40°C to +85°C, unless otherwise noted. Typical values are at V_{CC} = 2.7V, T_A = +25°C, unless otherwise noted.) (Note 1)

PARAMETER	SYMBOL	CONDITIONS	MIN	TYP	MAX	UNITS
Operating Voltage	V _{CC}		2.3		5.5	V
Quiescent Current	I _{CC}	I _{OUT-} = 0, logic inputs = 0 or V _{CC}	V _{CC} = 3.6V	160	300	μA
			V _{CC} = 5.5V	180	300	
Dynamic Supply Current	I _D	f _{SCLK} = 10MHz, C _{DOUT} = 50pF	V _{CC} = 3.6V	1.2		mA
			V _{CC} = 5.5V	1.6		
Thermal Shutdown		Power-save disable threshold (Note 2)		+130		°C
		Output disable threshold (Note 3)		+150		
Power-On Reset		Transform from high voltage to low voltage	0.6	1.2	2.0	V
Power-On Reset Hysteresis				140		mV
DIGITAL INPUTS (SCLK, DIN, \overline{CS}, LVL, A0, A1, A2, RESET, SET)						
Input Logic-High Voltage	V _{IH}	V _{CC} = 2.7V to 3.6V	2.0			V
		V _{CC} = 4.2V to 5.5V	2.4			
Input Logic-Low Voltage	V _{IL}	V _{CC} = 2.7V to 3.6V			0.6	V
		V _{CC} = 4.2V to 5.5V			0.8	
Input Logic Hysteresis	V _{HYST}			150		mV
Input Leakage Current	I _{LEAK}	Input voltages = 0 or 5.5V	-1.0	+0.01	+1.0	μA
Input Capacitance	C _{IN}			5		pF
DIGITAL OUTPUT (DOUT)						
DOUT Low Voltage	V _{OL}	I _{SINK} = 6mA			0.4	V
DOUT High Voltage	V _{OH}	I _{SOURCE} = 0.5mA	V _{CC} - 0.5			V

+3.3V/+5V, 8-Channel Relay Drivers with Fast Recovery Time and Power-Save Mode

MAX4822-MAX4825

ELECTRICAL CHARACTERISTICS (continued)

($V_{CC} = +2.7V$ to $+5.5V$, $T_A = -40^{\circ}C$ to $+85^{\circ}C$, unless otherwise noted. Typical values are at $V_{CC} = 2.7V$, $T_A = +25^{\circ}C$, unless otherwise noted.) (Note 1)

PARAMETER	SYMBOL	CONDITIONS	MIN	TYP	MAX	UNITS	
RELAY OUTPUT DRIVERS (OUT1–OUT8)							
OUT_ Drive Voltage, Power-Save On (MAX4822)	V _{OUTPS_}	V _{CC} = 2.7V (Note 4)	PS = 001	0.65 x V _{CC}	0.7 x V _{CC}	0.75 x V _{CC}	V
			PS = 010	0.55 x V _{CC}	0.6 x V _{CC}	0.65 x V _{CC}	
			PS = 011	0.45 x V _{CC}	0.5 x V _{CC}	0.55 x V _{CC}	
			PS = 100	0.35 x V _{CC}	0.4 x V _{CC}	0.45 x V _{CC}	
			PS = 101	0.25 x V _{CC}	0.3 x V _{CC}	0.35 x V _{CC}	
			PS = 110	0.15 x V _{CC}	0.2 x V _{CC}	0.25 x V _{CC}	
			PS = 111	0.05 x V _{CC}	0.1 x V _{CC}	0.15 x V _{CC}	
OUT_ Drive Voltage, Power-Save On (MAX4824)	V _{OUTPS_}	V _{CC} = 2.7V (Note 4)	0.35 x V _{CC}	0.4 x V _{CC}	0.45 x V _{CC}	V	
OUT_ On-Resistance	R _{ON}	V _{CC} = 2.7V, I _{OUT_} = 70mA		2.7	5.0	Ω	
OUT_ Off-Leakage Current	I _{LEAK}	V _{OUT_} = V _{CC} , all outputs off	-1		+1	μA	
Zener Clamping Voltage	V _{CLAMP}	I _{OUT_} = 70mA (Note 5)	7.0	9	10.5	V	
SPI TIMING (MAX4822/MAX4823)							
Turn-On Time (OUT_)	t _{ON}	From rising edge of \overline{CS} , R _L = 50Ω, C _L = 50pF			1.0	μs	
Turn-Off Time (OUT_)	t _{OFF}	From rising edge of \overline{CS} , R _L = 50Ω, C _L = 50pF			3.0	μs	
SCLK Frequency	f _{SCLK}		0		10	MHz	
Cycle Time	t _{CH} + t _{CL}		100			ns	
\overline{CS} Fall-to-SCLK Rise Setup	t _{CSS}		50			ns	
\overline{CS} Rise-to-SCLK Hold	t _{CSH}		50			ns	
SCLK High Time	t _{CH}		40			ns	
SCLK Low Time	t _{CL}		40			ns	
Data Setup Time	t _{DS}		20			ns	

+3.3V/+5V, 8-Channel Relay Drivers with Fast Recovery Time and Power-Save Mode

ELECTRICAL CHARACTERISTICS (continued)

($V_{CC} = +2.7V$ to $+5.5V$, $T_A = -40^{\circ}C$ to $+85^{\circ}C$, unless otherwise noted. Typical values are at $V_{CC} = 2.7V$, $T_A = +25^{\circ}C$, unless otherwise noted.) (Note 1)

PARAMETER	SYMBOL	CONDITIONS	MIN	TYP	MAX	UNITS
Data Hold Time	t_{DH}		0			ns
SCLK Fall to DOUT Valid	t_{DO}	50% of SCLK to (V_{IH} , V_{IL} of DIN), $C_L = 50pF$		17	28	ns
Rise Time (DIN, SCLK, \overline{CS} , \overline{SET} , \overline{RESET})	t_{SCR}	20% of V_{CC} to 70% of V_{CC} , $C_L = 50pF$ (Note 6)			2	μs
Fall Time (DIN, SCLK, \overline{CS} , \overline{RESET} , SET)	t_{SCF}	20% of V_{CC} to 70% of V_{CC} , $C_L = 50pF$ (Note 6)			2	μs
\overline{RESET} Minimum Pulse Width	t_{RW}		70			ns
\overline{SET} Minimum Pulse Width	t_{SW}		70			ns
\overline{CS} Minimum Pulse Width	t_{CSW}		40			ns
PARALLEL TIMING (MAX4824/MAX4825)						
Turn-On Time	t_{ON}	From rising edge of \overline{CS} , $R_L = 50\Omega$, $C_L = 50pF$			1	μs
Turn-Off Time	t_{OFF}	From rising edge of \overline{CS} , $R_L = 50\Omega$, $C_L = 50pF$			3	μs
LVL Setup Time	t_{LS}		20			ns
LVL Hold Time	t_{LH}		0			ns
Address to \overline{CS} Setup Time	t_{AS}		20			ns
Address to \overline{CS} Hold Time	t_{AH}		0			ns
Rise Time (A2, A1, A0, LVL)	t_{SCR}	20% of V_{CC} to 70% of V_{CC} , $C_L = 50pF$ (Note 6)			2	μs
Fall Time (A2, A1, A0, LVL)	t_{SCF}	20% of V_{CC} to 70% of V_{CC} , $C_L = 50pF$ (Note 6)			2	μs
\overline{RESET} Pulse Width	t_{RW}		70			ns
\overline{SET} Pulse Width	t_{SW}		70			ns
\overline{CS} Minimum Pulse Width	t_{CSW}		40			ns
POWER-SAVE TIMING (MAX4822/MAX4824)						
Power-Save Delay Time	t_{PS}	Variation from typical value, $C_L = 100nF$ (Note 7)	1.6	3.2	5.4	ms
Minimum PSAVE Low Time to Power-Save Reset	t_{PSR}			2	3.5	ms

Note 1: Specifications at $-40^{\circ}C$ are guaranteed by design and not production tested.

Note 2: Thermal shutdown disables power save from all channels to reduce power dissipation inside the device.

Note 3: Thermal shutdown turns off all channels.

Note 4: The circuit can set the output voltage in power-save mode only if $I_{OUT} \times R_{ON} < V_{OUTP}$.

Note 5: After relay turn-off, inductive kickback can momentarily cause the OUT_{-} voltage to exceed V_{CC} . This is considered part of normal operation and does not damage the device.

Note 6: Guaranteed by design.

Note 7: For other capacitance values, use the equation $t_{PS} = 32 \times C$.

+3.3V/+5V, 8-Channel Relay Drivers with Fast Recovery Time and Power-Save Mode

Typical Operating Characteristics

($V_{CC} = 3.3V$, $T_A = +25^\circ C$, unless otherwise noted.)

MAX4822-MAX4825

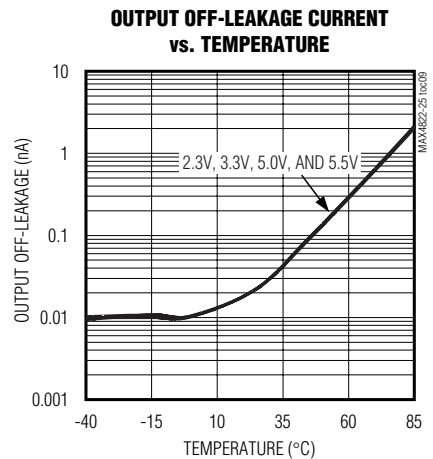
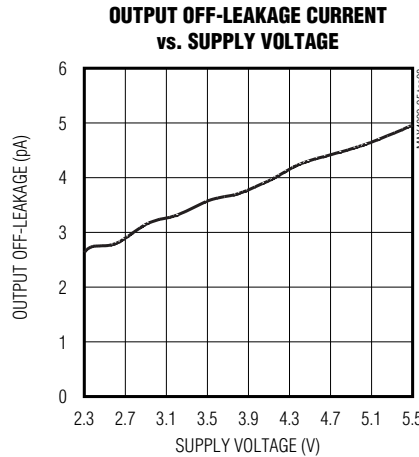
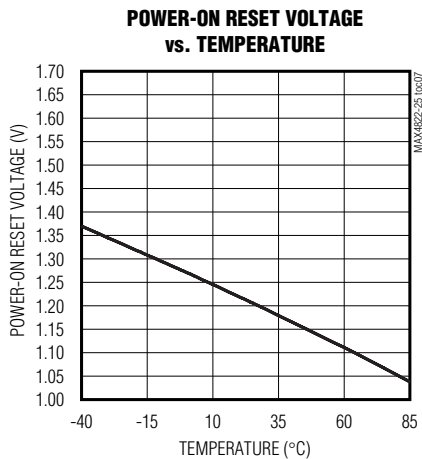
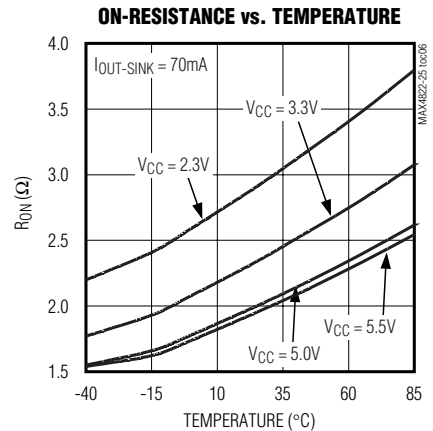
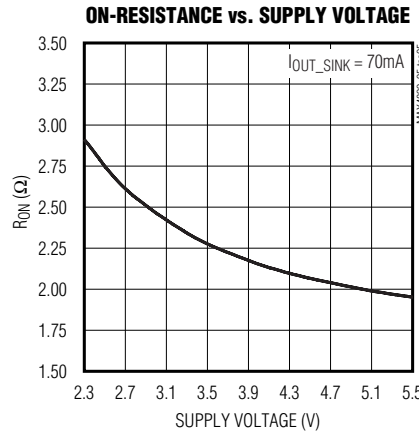
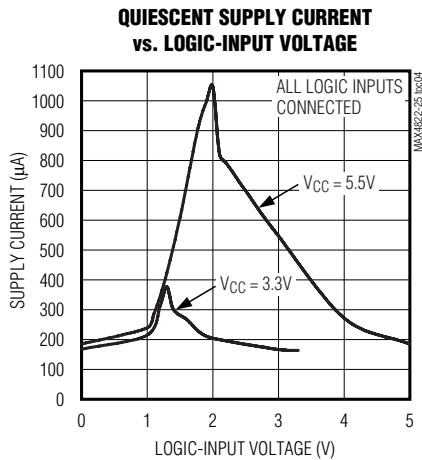
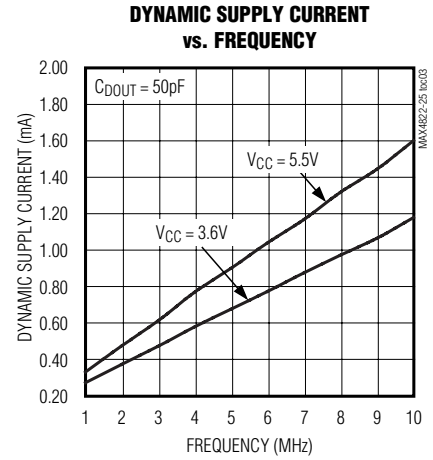
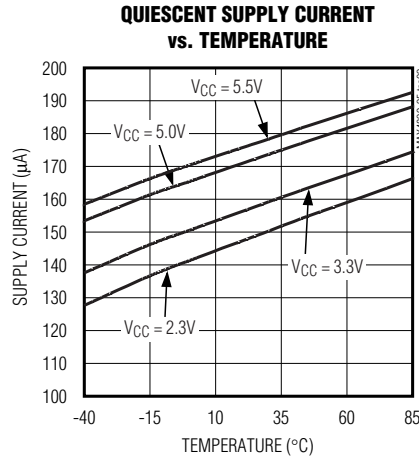
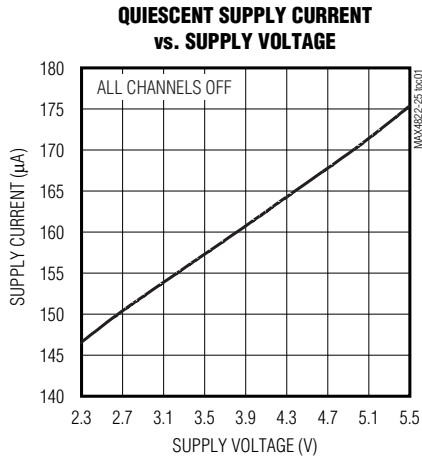

+3.3V/+5V, 8-Channel Relay Drivers with Fast Recovery Time and Power-Save Mode

Typical Operating Characteristics (continued)

(V_{CC} = 3.3V, T_A = +25°C, unless otherwise noted.)

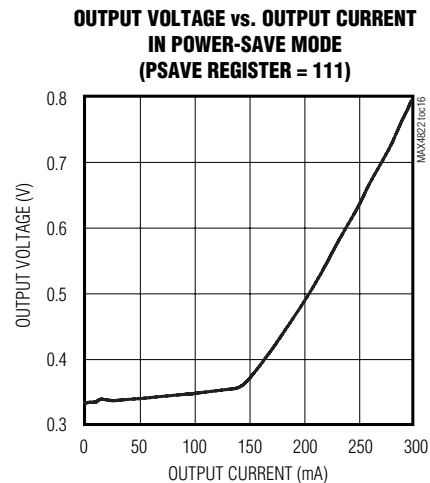
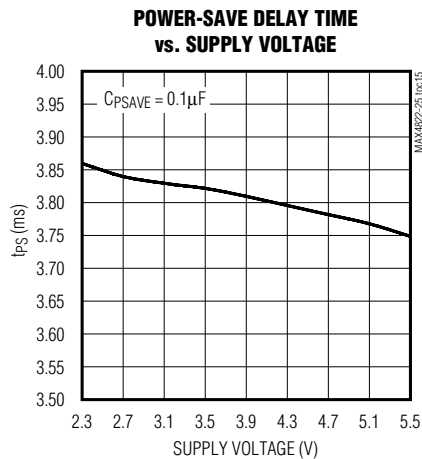
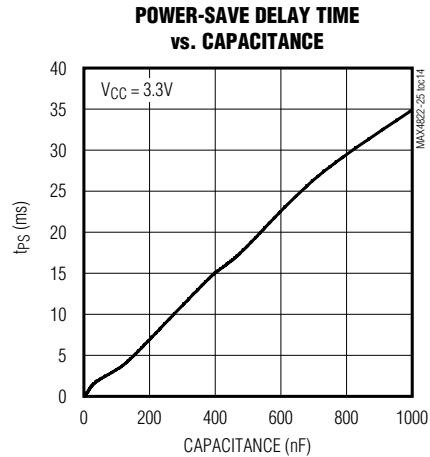
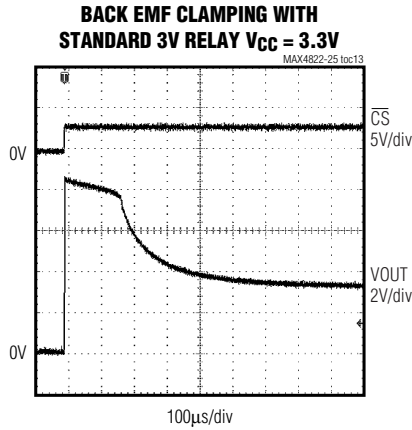
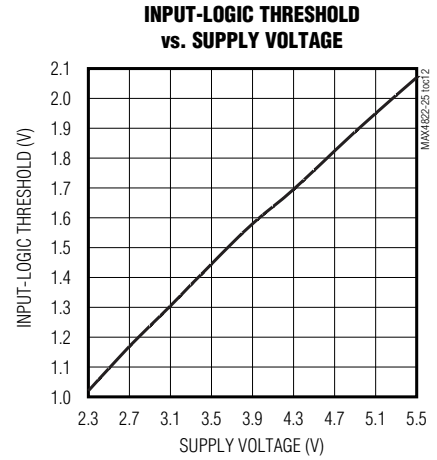
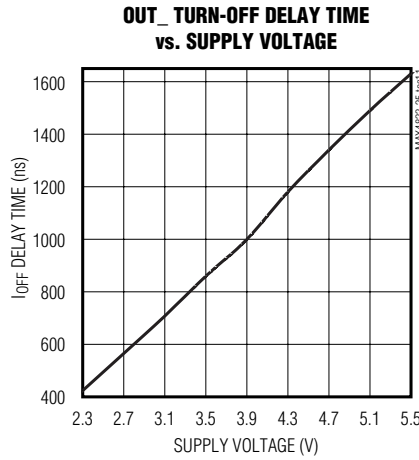
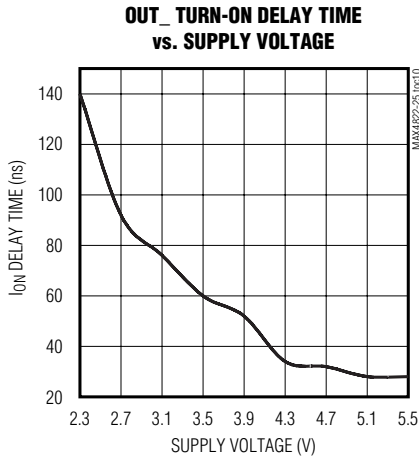

+3.3V/+5V, 8-Channel Relay Drivers with Fast Recovery Time and Power-Save Mode

MAX4822/MAX4823 Pin Description

MAX4822-MAX4825

PIN		NAME	FUNCTION
MAX4822	MAX4823		
1	1	$\overline{\text{RESET}}$	Reset Input. Drive $\overline{\text{RESET}}$ low to clear all latches and registers (all outputs are high impedance). $\overline{\text{RESET}}$ overrides all other inputs. If $\overline{\text{RESET}}$ and $\overline{\text{SET}}$ are pulled low at the same time, then $\overline{\text{RESET}}$ takes precedence.
2	2	$\overline{\text{CS}}$	Chip-Select Input. Drive $\overline{\text{CS}}$ low to select the device. When $\overline{\text{CS}}$ is low, data at DIN is clocked into the shift register on SCLK's rising edge. Drive $\overline{\text{CS}}$ from low to high to latch the data to the registers and activate the relay outputs.
3	3	DIN	Serial Data Input
4	4	SCLK	Serial Clock Input
5	5	DOUT	Serial Data Output. DOUT is the output of the shift register. DOUT can be used to daisy-chain multiple MAX4822/MAX4823 devices. The data at DOUT appears synchronous to SCLK's falling edge.
6	6, 13	N.C.	No Connection. Not internally connected.
7	7	GND	Ground
8	8	OUT8	Open-Drain Output 8. Connect OUT8 to the low side of a relay coil. This output is pulled to PGND when activated, but otherwise is high impedance.
9	9	OUT7	Open-Drain Output 7. Connect OUT7 to the low side of a relay coil. This output is pulled to PGND when activated, but otherwise is high impedance.
10, 16	10, 16	PGND	Power Ground. PGND is a return for the output sinks. Connect PGND pins together and to GND.
11	11	OUT6	Open-Drain Output 6. Connect OUT6 to the low side of a relay coil. This output is pulled to PGND when activated, but otherwise is high impedance.
12	12	OUT5	Open-Drain Output 5. Connect OUT5 to the low side of a relay coil. This output is pulled to PGND when activated, but otherwise is high impedance.
13	—	PSAVE	Power-Save Control. Connect a timing capacitor from PSAVE to ground. The capacitor value determines power-save timing as explained under the <i>Applications Information</i> section. PSAVE can also be driven externally to control power-save mode asynchronously. When asserted high, PSAVE reduces the current to all active outputs as determined by the <i>Power-Save Configuration Register</i> (see Figure 1). To disable power-save mode in all channels, drive PSAVE low for at least 3ms after the last output setting.
14	14	OUT4	Open-Drain Output 4. Connect OUT4 to the low side of a relay coil. This output is pulled to PGND when activated, but otherwise is high impedance.
15	15	OUT3	Open-Drain Output 3. Connect OUT3 to the low side of a relay coil. This output is pulled to PGND when activated, but otherwise is high impedance.
17	17	OUT2	Open-Drain Output 2. Connect OUT2 to the low side of a relay coil. This output is pulled to PGND when activated, but otherwise is high impedance.
18	18	OUT1	Open-Drain Output 1. Connect OUT1 to the low side of a relay coil. This output is pulled to PGND when activated, but otherwise is high impedance.

+3.3V/+5V, 8-Channel Relay Drivers with Fast Recovery Time and Power-Save Mode

MAX4822/MAX4823 Pin Description (continued)

PIN		NAME	FUNCTION
MAX4822	MAX4823		
19	19	V _{CC}	Input Supply Voltage. Bypass V _{CC} to GND with a 0.1µF capacitor.
20	20	$\overline{\text{SET}}$	Set Input. Drive $\overline{\text{SET}}$ low to set all latches and registers high (all outputs are low impedance). $\overline{\text{SET}}$ overrides all parallel and serial control inputs. RESET overrides $\overline{\text{SET}}$ under all conditions.
EP	EP	EP	Exposed Pad. Connect exposed paddle to GND.

MAX4824/MAX4825 Pin Description

PIN		NAME	FUNCTION
MAX4824	MAX4825		
1	1	$\overline{\text{RESET}}$	Reset Input. Drive $\overline{\text{RESET}}$ low to clear all latches and registers (all outputs are high impedance). $\overline{\text{RESET}}$ overrides all other inputs. If $\overline{\text{RESET}}$ and $\overline{\text{SET}}$ are pulled low at the same time, then $\overline{\text{RESET}}$ takes precedence.
2	2	$\overline{\text{CS}}$	Chip-Select Input. Drive $\overline{\text{CS}}$ low to select the device. The $\overline{\text{CS}}$ falling edge latches the output address (A0, A1, A2). The $\overline{\text{CS}}$ rising edge latches level data (LVL).
3	3	LVL	Level Input. LVL determines whether the selected address is switched on or off. Logic-high on LVL switches on the addressed output. A logic-low on LVL switches off the addressed output.
4	4	A0	Digital Address 0 Input. (See Figure 3 for address mapping.)
5	5	A1	Digital Address 1 Input. (See Figure 3 for address mapping.)
6	6	A2	Digital Address 2 Input. (See Figure 3 for address mapping.)
7	7	GND	Ground
8	8	OUT8	Open-Drain Output 8. Connect OUT8 to the low side of a relay coil. This output is pulled to PGND when activated, but otherwise is high impedance.
9	9	OUT7	Open-Drain Output 7. Connect OUT7 to the low side of a relay coil. This output is pulled to PGND when activated, but otherwise is high impedance.
10, 16	10, 16	PGND	Power Ground. PGND is a return for the output sinks. Connect PGND pins together and to GND.
11	11	OUT6	Open-Drain Output 6. Connect OUT6 to the low side of a relay coil. This output is pulled to PGND when activated, but otherwise is high impedance.
12	12	OUT5	Open-Drain Output 5. Connect OUT5 to the low side of a relay coil. This output is pulled to PGND when activated, but otherwise is high impedance.

+3.3V/+5V, 8-Channel Relay Drivers with Fast Recovery Time and Power-Save Mode

MAX4824/MAX4825 Pin Description (continued)

MAX4822-MAX4825

PIN		NAME	FUNCTION
MAX4824	MAX4825		
13	—	PSAVE	Power-Save Control. Connect a timing capacitor from PSAVE to ground. The capacitor value determines power-save timing as explained under the <i>Applications Information</i> section. PSAVE can also be driven externally to control power-save mode asynchronously. When PSAVE is asserted high, the current through the coils is reduced to 60% of the initial nominal current value. To disable power-save mode in all channels, drive PSAVE low for at least 3ms after last output setting.
14	14	OUT4	Open-Drain Output 4. Connect OUT4 to the low side of a relay coil. This output is pulled to PGND when activated, but otherwise is high impedance.
15	15	OUT3	Open-Drain Output 3. Connect OUT3 to the low side of a relay coil. This output is pulled to PGND when activated, but otherwise is high impedance.
17	17	OUT2	Open-Drain Output 2. Connect OUT2 to the low side of a relay coil. This output is pulled to PGND when activated, but otherwise is high impedance.
18	18	OUT1	Open-Drain Output 1. Connect OUT1 to the low side of a relay coil. This output is pulled to PGND when activated, but otherwise is high impedance.
19	19	VCC	Input Supply Voltage. Bypass VCC to GND with a 0.1µF capacitor.
20	20	$\overline{\text{SET}}$	Set Input. Drive $\overline{\text{SET}}$ low to set all latches and registers high (all outputs are low impedance). $\overline{\text{SET}}$ overrides all parallel and serial control inputs. $\overline{\text{RESET}}$ overrides $\overline{\text{SET}}$ under all conditions.
—	13	N.C.	No Connection. Not internally connected.
EP	EP	EP	Exposed Pad. Connect exposed paddle to ground.

Detailed Description

Serial Interface (MAX4822/MAX4823)

Depending on the MAX4822/MAX4823 device, the serial interface can be controlled by either 8- or 16-bit words as depicted in Figures 1 and 2. The MAX4823 does not support power-save mode, so the serial interface consists of an 8-bit-only shift register for faster control.

The MAX4822 consists of a 16-bit shift register and parallel latch controlled by SCLK and CS. The input to the shift register is a 16-bit word. In the MAX4822, the first 8 bits determine the register address and are followed

by 8 bits of data as depicted in Figure 1. Bit A7 corresponds to the MSB of the 8-bit register address in Figure 1, while bit D7 corresponds to the MSB of the 8 bits of data in the same Figure 1.

The MAX4823 consists of an 8-bit shift register and parallel latch controlled by SCLK and CS. The input to the shift register is an 8-bit word. Each data bit controls one of the eight outputs, with the most significant bit (D7) corresponding to OUT8, and the least significant bit (D0) corresponding to OUT1 (see Figure 2).

+3.3V/+5V, 8-Channel Relay Drivers with Fast Recovery Time and Power-Save Mode

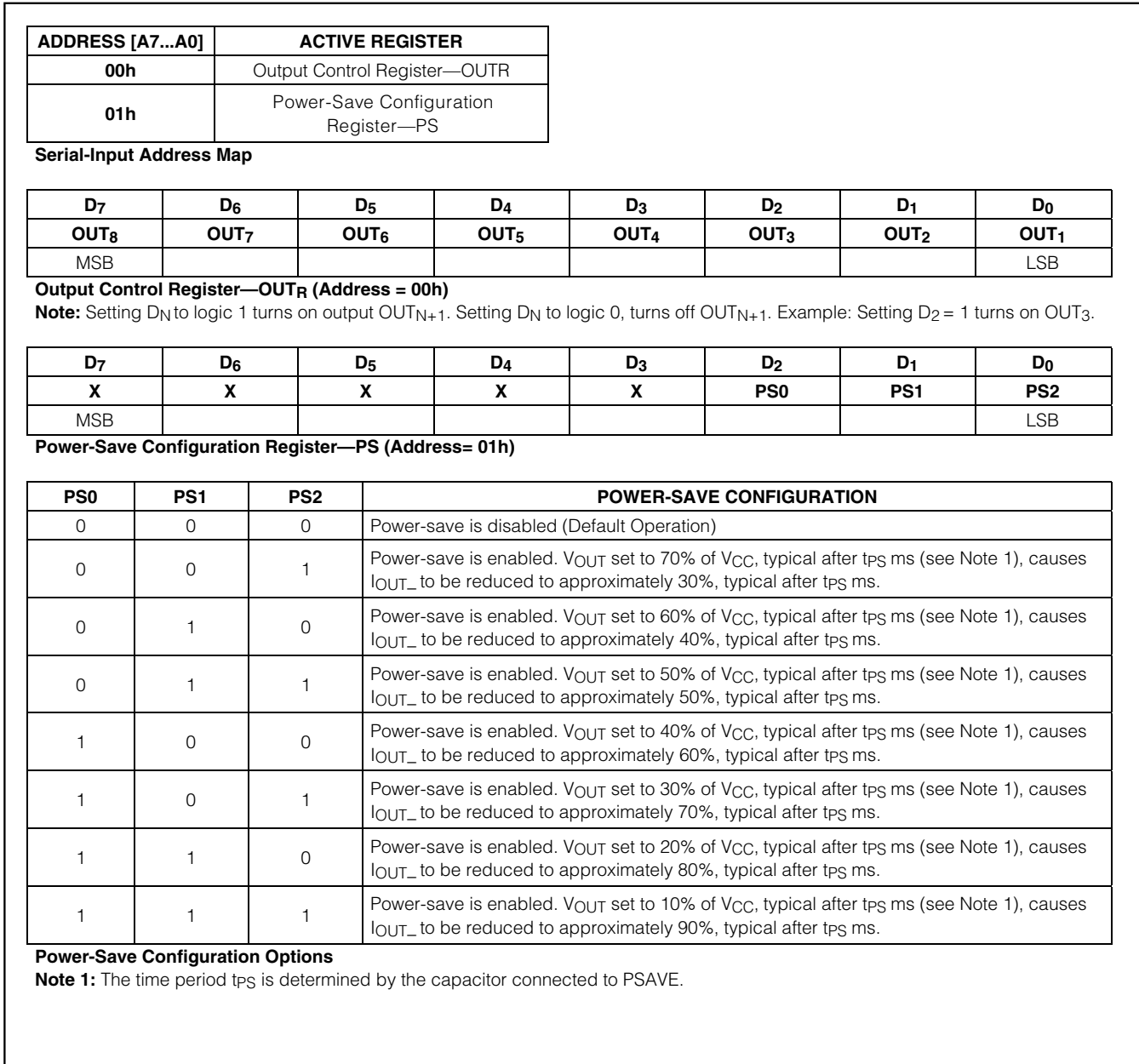

Figure 1. 16-Bit Register Map for MAX4822

When \overline{CS} is low (MAX4822/MAX4823 device is selected), data at DIN is clocked into the shift register synchronously with SCLK's rising edge. Driving \overline{CS} from low to high latches the data in the shift register (Figures 5 and 6).

DOUT is the output of the shift register. Data appears on DOUT synchronously with SCLK's falling edge and is identical to the data at DIN delayed by eight clock cycles for the MAX4823, or 16 clock cycles for the MAX4822. When shifting the input data, A7 is the first input bit in and out of the shift register for the MAX4822 device. D7 is the first bit in or out of the shift register for

+3.3V/+5V, 8-Channel Relay Drivers with Fast Recovery Time and Power-Save Mode

MSB							LSB
D7	D6	D5	D4	D3	D2	D1	D0
OUT8	OUT7	OUT6	OUT5	OUT4	OUT3	OUT2	OUT1

Note: Setting D_N to logic 1 turns on output OUT_{N+1} . Setting D_N to logic 0 turns off output OUT_{N+1} .
Example: Setting the $D_2 = 1$ turns OUT_3 on.

Figure 2. 8-Bit Register Map for MAX4823

A2	A1	A0	OUTPUT
Low	Low	Low	OUT1
Low	Low	High	OUT2
Low	High	Low	OUT3
Low	High	High	OUT4
High	Low	Low	OUT5
High	Low	High	OUT6
High	High	Low	OUT7
High	High	High	OUT8

Figure 3. Register Address Map for MAX4824/MAX4825

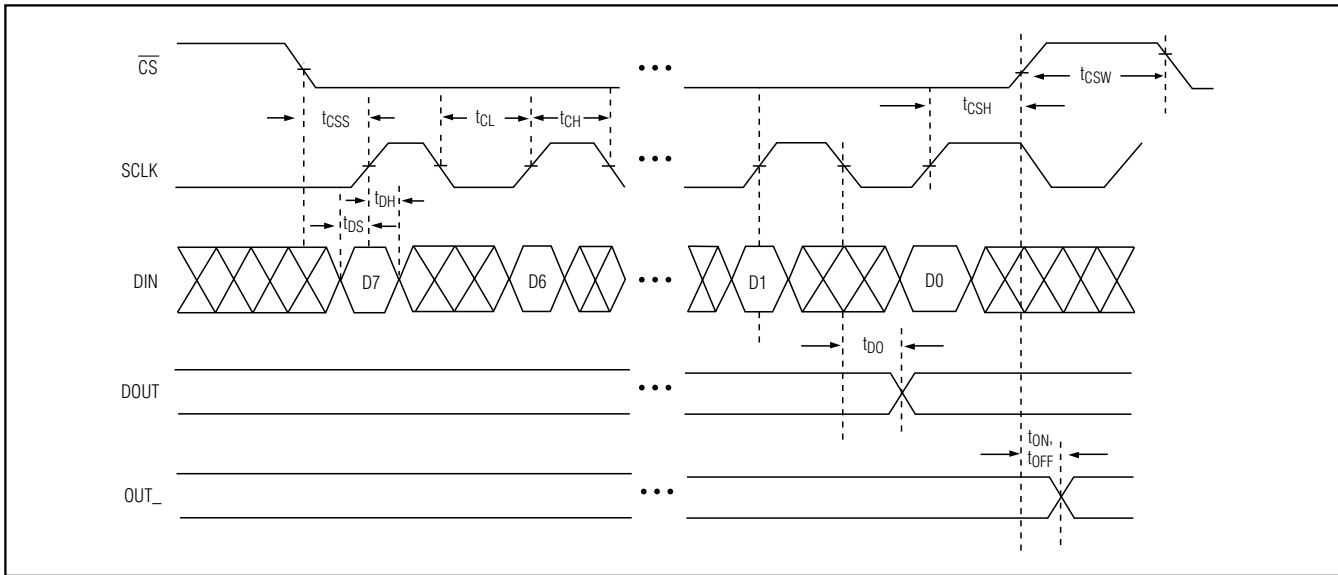

Figure 4. 3-Wire Serial-Interface Timing Diagram

the MAX4823 device. If the address $A0.....A7$ is not 00h or 01h, then the outputs and the PSAVE configuration register are not updated. The address is stored in the shift register only.

While \overline{CS} is low, the OUT_* outputs always remain in their previous state. For the MAX4823, drive \overline{CS} high after 8 bits of data have been shifted in to update the output state of the MAX4823, and to further inhibit data from entering the shift register. For the MAX4822, drive \overline{CS} high after 16 bits of data have been shifted in to update the output state of the MAX4822, and to further inhibit data from entering the shift register. When \overline{CS} is high, transitions at DIN and SCLK have no effect on the output, and the first input bit A7 (or D7) is present at DOUT.

For the MAX4822, if the number of data bits entered while \overline{CS} is low is greater or less than 16, the shift register contains only the last 16 bits, regardless of when they were entered. For the MAX4823, if the number of data bits entered while \overline{CS} is low is greater or less than 8, the shift register contains only the last 8 data bits, regardless of when they were entered.

Parallel Interface (MAX4824/MAX4825)

The parallel interface consists of 3 address bits ($A0, A1, A2$) and one level selector bit (LVL). The address bits determine which output is updated, and the level bit determines whether the addressed output is switched on (LVL = high) or off (LVL = low). When \overline{CS} is high, the address and level bits have no effect on the state of the outputs. Driving \overline{CS} from low to high latches

+3.3V/+5V, 8-Channel Relay Drivers with Fast Recovery Time and Power-Save Mode

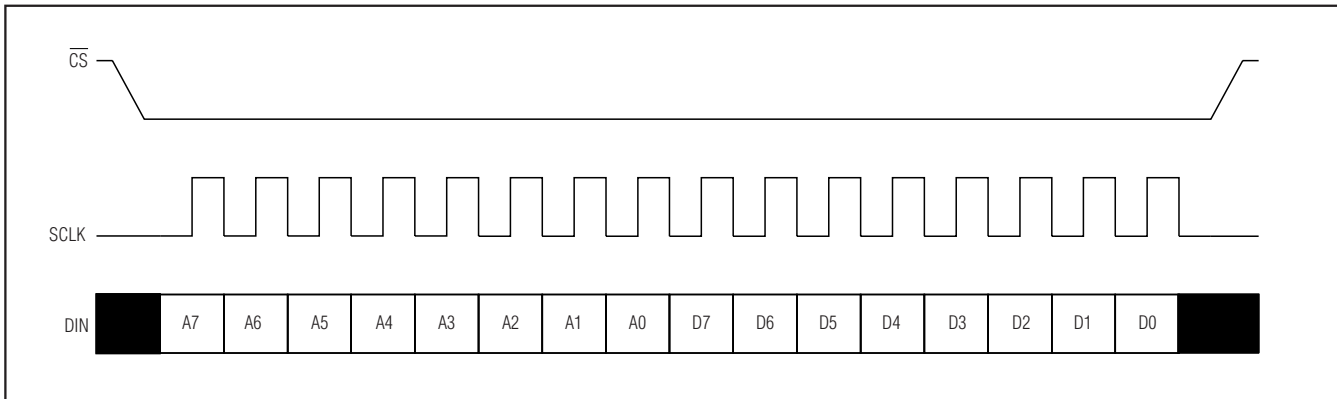

Figure 5. 3-Wire Serial-Interface Operation for MAX4822

level data to the parallel register and updates the state of the outputs. Address data entered after \overline{CS} is pulled low is not reflected in the state of the outputs following the next low-to-high transition on \overline{CS} (Figure 7).

SET/RESET Functions

The MAX4822-MAX4825 feature set and reset inputs that allow simultaneous turn-on or turn-off of all outputs using a single control line. Drive \overline{SET} low to set all latches and registers to 1 and turn all outputs on. \overline{SET} overrides all serial/parallel control inputs. Drive \overline{RESET} low to clear all latches and registers and to turn all outputs off. \overline{RESET} overrides all other inputs including \overline{SET} .

Power-On Reset

The MAX4822-MAX4825 feature power-on reset. The power-on reset function causes all latches to be cleared automatically upon power-up. This ensures that all outputs come up in the off or high-impedance state.

Applications Information

Daisy Chaining

The MAX4822/MAX4823 feature a digital output (DOUT) that provides a simple way to daisy chain multiple devices. This feature allows driving large banks of relays using only a single serial interface. To daisy chain multiple devices, connect all \overline{CS} inputs together, and connect the DOUT of one device to the DIN of another device (see Figure 8). During operation, a stream of serial data is shifted through the MAX4822/MAX4823 devices in series. When \overline{CS} goes high, all outputs update simultaneously.

The MAX4822/MAX4823 can also be used in a slave configuration that allows individual addressing of devices. Connect all the DIN inputs together, and use

the \overline{CS} input to address one device at a time. Drive \overline{CS} low to select a slave and input the data into the shift register. Drive \overline{CS} high to latch the data and turn on the appropriate outputs. Typically, in this configuration only one slave is addressed at a time.

Power-Save Mode

The MAX4822/MAX4824 feature a unique power-save mode where the relay current, after activation, can be reduced to a level just above the relay hold-current threshold. This mode keeps the relay activated while significantly reducing the power consumption.

In serial mode (MAX4822), choose between seven current levels ranging from 30% to 90% of the nominal current in 10% increments. The actual percentage is determined by the power-save configuration register (Figure 1).

In parallel mode (MAX4824), the power-save current is fixed at 60% of the nominal current.

Power-Save Timer

Every time there is a write operation to the device (\overline{CS} transitions from low to high), the MAX4822/MAX4824 start charging the capacitor connected to PSAVE. The serial power-save implementation is such that a write operation does not change the state of channels already in power-save mode (unless the write turns the channel OFF).

After a certain time period, t_{PS} (determined by the capacitor value), the capacitor reaches a voltage threshold that sets all active outputs to power-save mode. The t_{PS} period should be made long enough to allow the relay to turn on completely. The time period t_{PS} can be adjusted by using different capacitor values

+3.3V/+5V, 8-Channel Relay Drivers with Fast Recovery Time and Power-Save Mode

connected to PSAVE. The value t_{PS} is given by the following formula:

$$t_{PS} = 32 \times C$$

where C is in μF and t_{PS} is in ms.

For example, if the desired t_{PS} is 20ms, then the required capacitor value is $20 / 32 = 0.625\mu\text{F}$.

Power-Save Mode Accuracy

The current through the relay is controlled by setting the voltage at OUT_i to a percentage of the V_{CC} supply as specified under the *Electrical Characteristics* and in the register description. The current through the relay (I_{OUT}) depends on the switch on-resistance, R_{ON} , in addition to the relay resistance R_R according to the following relation:

$$I_{OUT} = V_{CC} / (R_{ON} + R_R)$$

The power-save, current-setting I_{PS} depends on the fraction α of the supply voltage V_{CC} that is set by the loop depending on the following relation:

$$I_{PS} = V_{CC} - (\alpha \times V_{CC}) / R_R$$

Therefore:

$$I_{PS} / I_{OUT} = (1 - \alpha) \times (1 + R_{ON} / R_R)$$

This relation shows how the fraction of reduction in the current depends on the switch on-resistance, as well as from the accuracy of the voltage setting (α). The higher the R_{ON} with respect to R_R , the higher the inaccuracy. This is particularly true at low voltage when the relay resistance is low (less than 40Ω) and the switch can account for up to 10% of the total resistance. In addition, when the supply-voltage setting (α) is low (10% or 20%) and the supply voltage (V_{CC}) is low, the voltage drop across the switch ($I_{OUT} \times R_{ON}$) may already exceed, or may be very close to, the desired voltage-setting value.

Daisy Chaining and Power-Save Mode

In a normal configuration using the power-save feature, several MAX4822s can be daisy chained as shown in Figure 9. For each MAX4822, the power-save timing t_{PD} (time it takes to reduce the relay current once the relay is actuated) is controlled by the capacitor connected to PSAVE.

An alternative configuration that eliminates the PSAVE capacitors uses a common PSAVE control line driven by an open-drain n-channel MOSFET (Figure 10). In this configuration, the PSAVE inputs are connected together to asynchronously control the power-save timing for all the MAX4822s in the chain. The $\mu\text{C}/\mu\text{P}$ drives the n-channel MOSFET low for the duration of a write cycle to the SPI chain, plus some delay time to allow the relays to close.

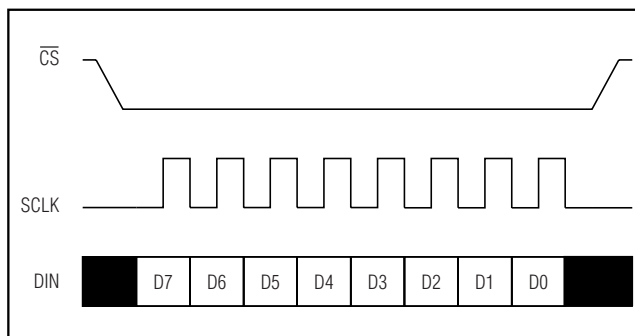

Figure 6. 3-Wire Serial-Interface Operation for the MAX4823

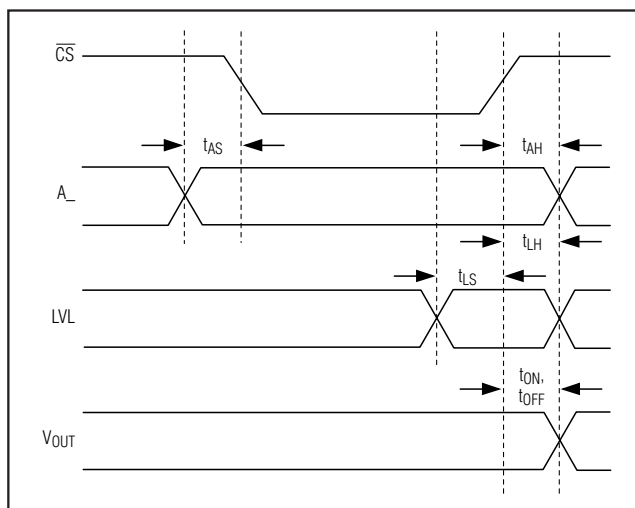

Figure 7. Parallel-Interface Timing Diagram

(This time is typically specified in the relay data sheet.) Once this delay time has elapsed, the n-channel MOSFET is turned off, allowing the MAX4822's internal $35\mu\text{A}$ pullup current to raise PSAVE to a logic-high level, activating the power-save mode in all active outputs.

MOSFET Selection

In the daisy-chain configuration of Figure 10, the n-channel MOSFET drives PSAVE low. When the n-channel MOSFET is turned off, PSAVE is pulled high by an internal $35\mu\text{A}$ pullup in each MAX4822, and the power-save mode is enabled. Because of the paralleled PSAVE pullup currents, the required size of the n-channel MOSFET depends upon the number of MAX4822 devices in the chain. Determine the size of the n-channel MOSFET by the following relation:

$$R_{ON} < 1428 / N$$

+3.3V/+5V, 8-Channel Relay Drivers with Fast Recovery Time and Power-Save Mode

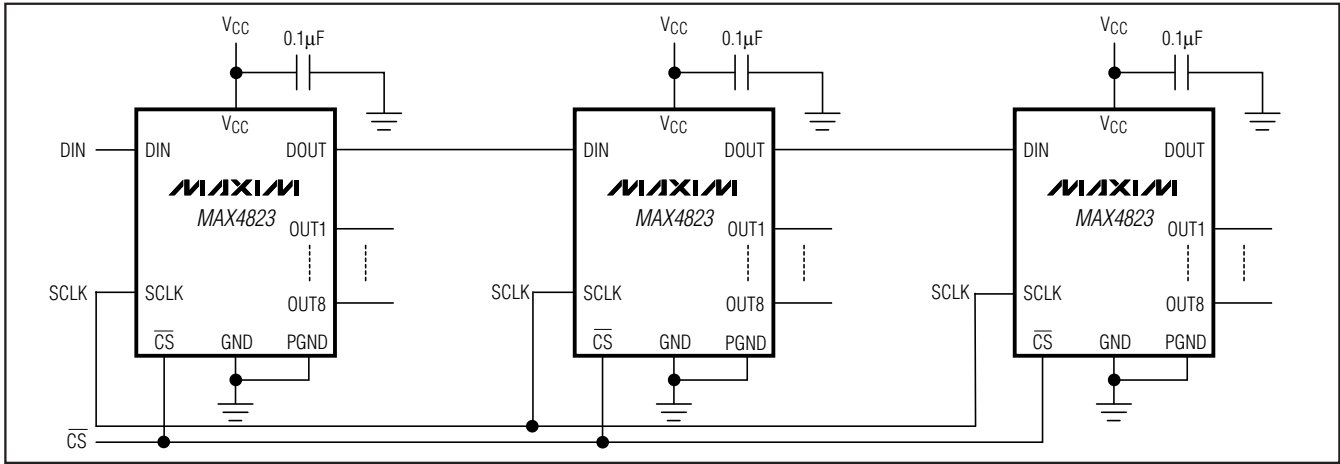

Figure 8. Daisy-Chain Configuration

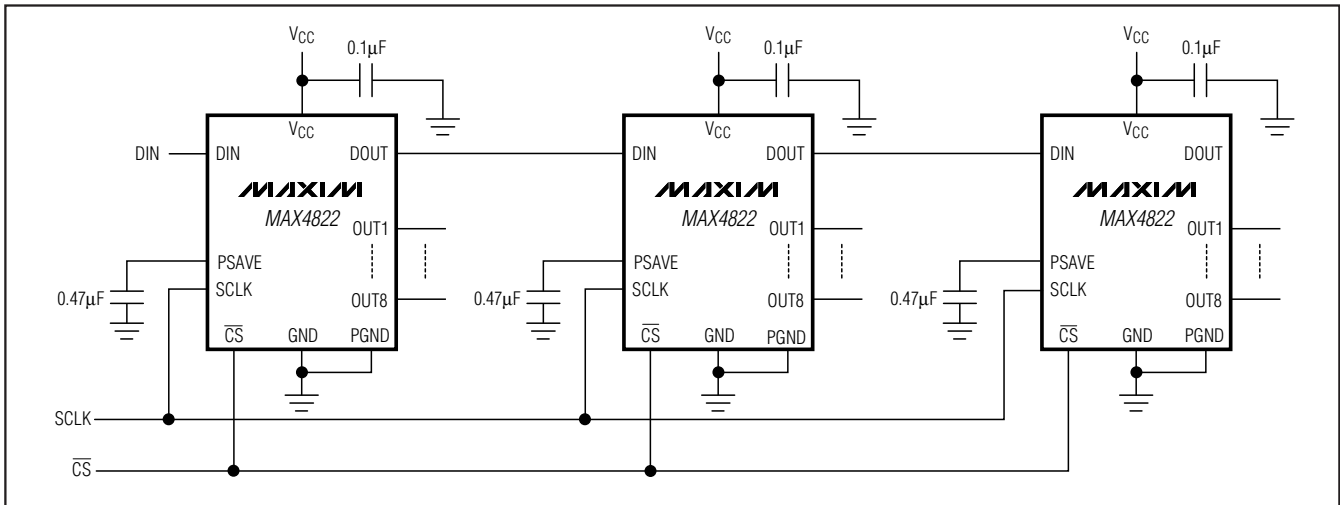

Figure 9. Daisy-Chain MAX4822s with a Capacitor Connected to PSAVE

where N is the total number of MAX4822 devices in a single chain, and R_{ON} is the on-resistance of the n-channel MOSFET in Ω s.

For example, if $N = 10$:

$$R_{ON} < 142\Omega$$

An n-channel MOSFET with R_{ON} less than 142Ω is required for a daisy chain of 10 MAX4822 devices.

Inductive Kickback Protection with Fast Recovery Time

The MAX4822-MAX4825 feature built-in inductive kickback protection to reduce the voltage spike on OUT_n generated by a relay's coil inductance when the output is suddenly switched off. An internal Zener clamp allows the inductor current to flow back to ground. The Zener configuration significantly reduces the recovery time (time it takes to turn off the relay) when compared to protection configurations with just one diode across the coil.

+3.3V/+5V, 8-Channel Relay Drivers with Fast Recovery Time and Power-Save Mode

MAX4822-MAX4825

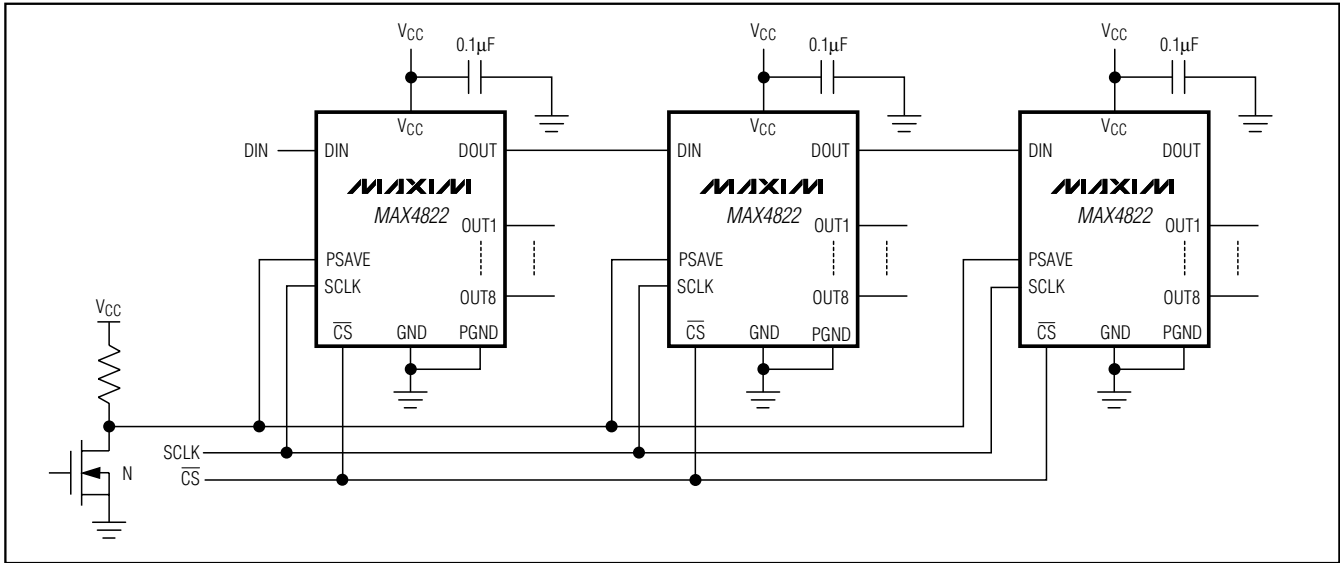

Figure 10. Daisy-Chaining MAX4822s with a PSAVE Connected to an n-Channel MOSFET

Chip Information

TRANSISTOR COUNT: 5799

PROCESS: BiCMOS

+3.3V/+5V, 8-Channel Relay Drivers with Fast Recovery Time and Power-Save Mode

MAX4822/MAX4823 Functional Diagram (Serial Interface)

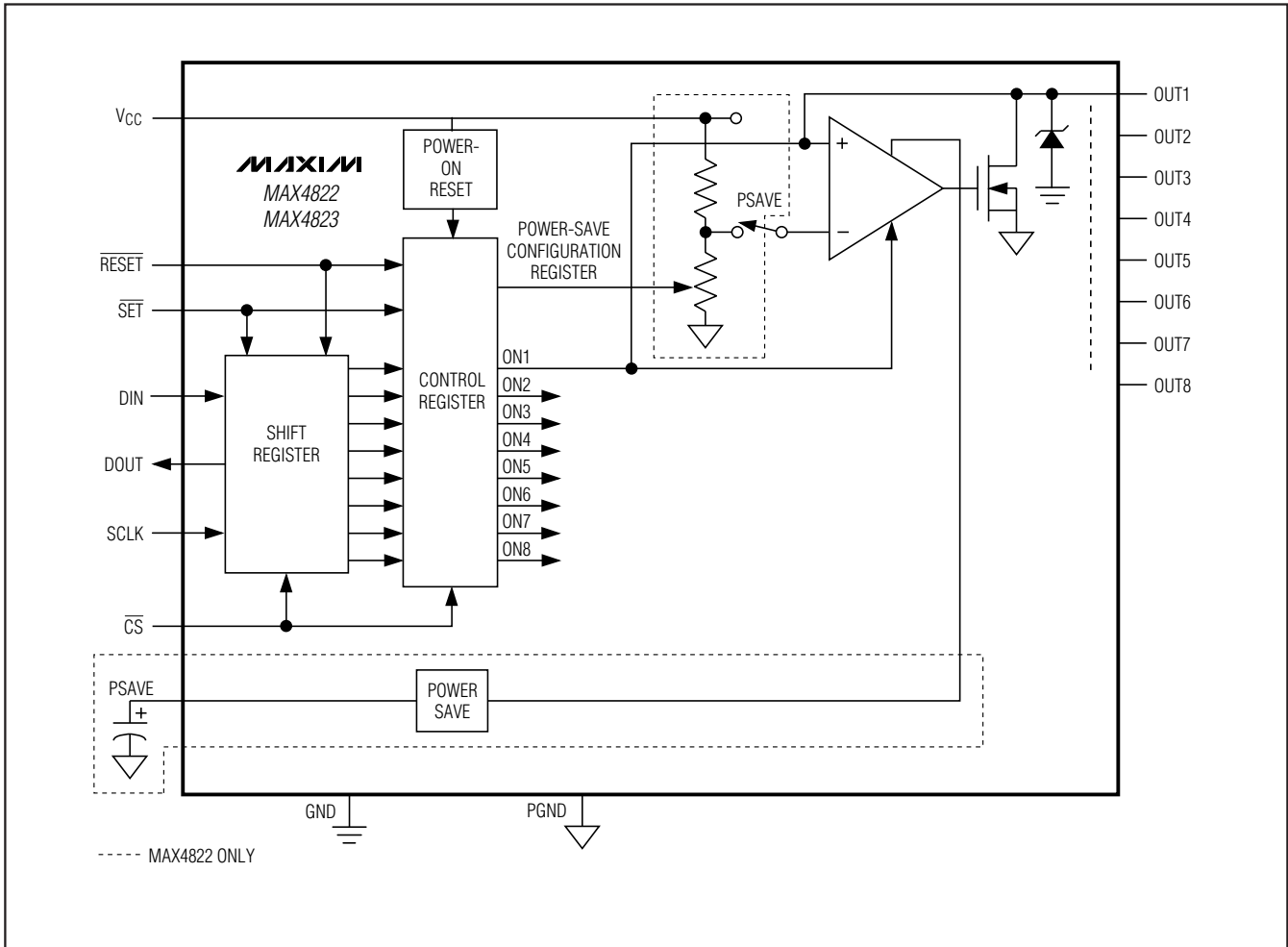

+3.3V/+5V, 8-Channel Relay Drivers with Fast Recovery Time and Power-Save Mode

MAX4824/MAX4825 Functional Diagram (Parallel Interface)

MAX4822-MAX4825

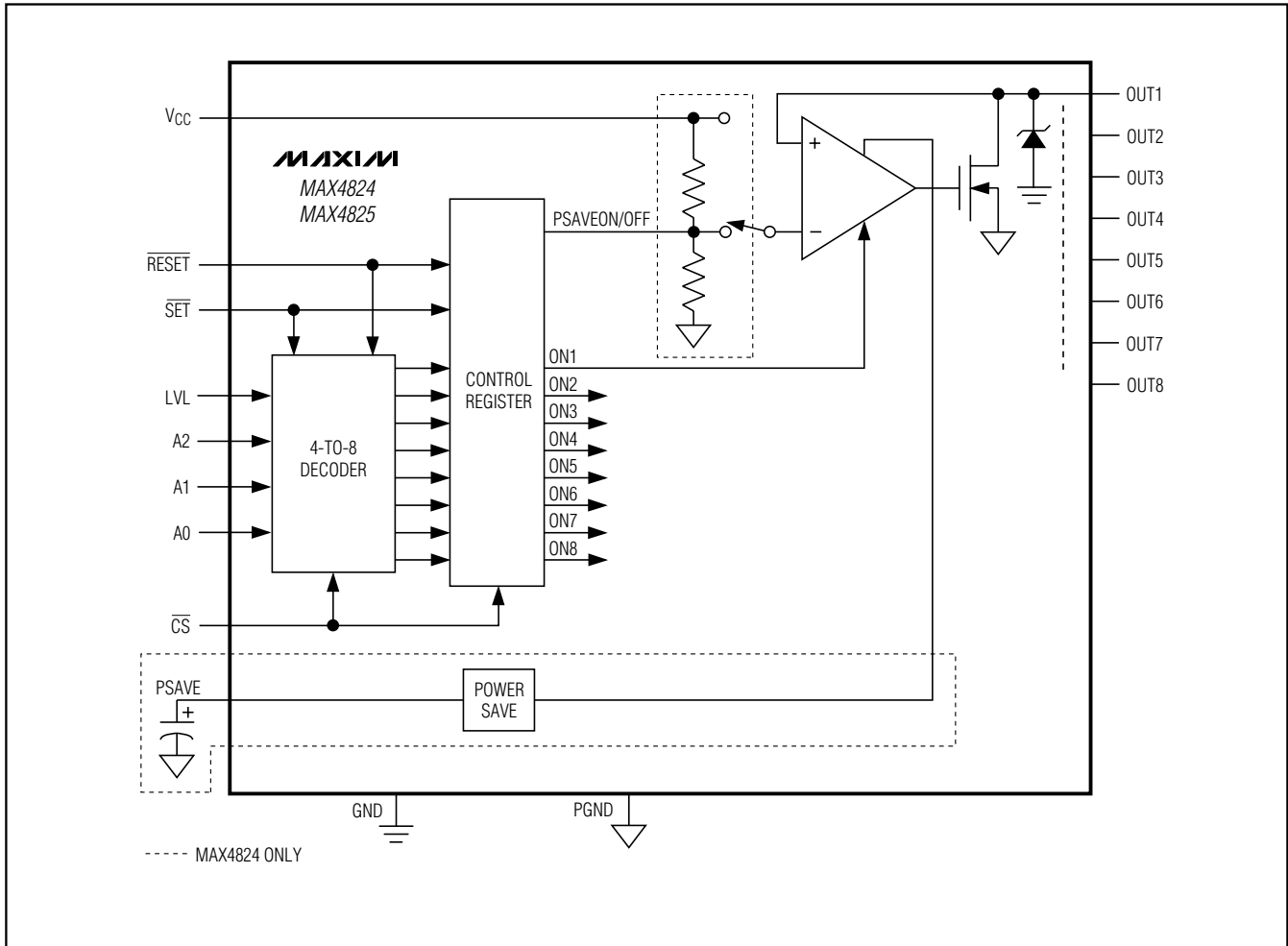

+3.3V/+5V, 8-Channel Relay Drivers with Fast Recovery Time and Power-Save Mode

Pin Configurations

TOP VIEW

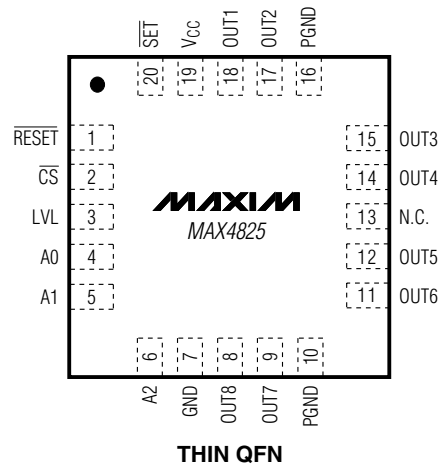
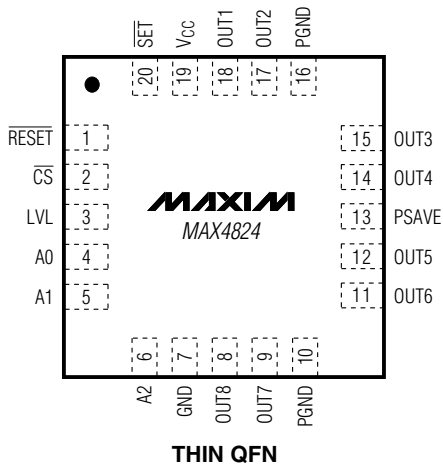
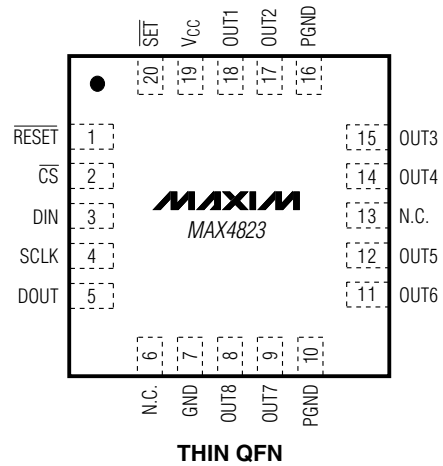
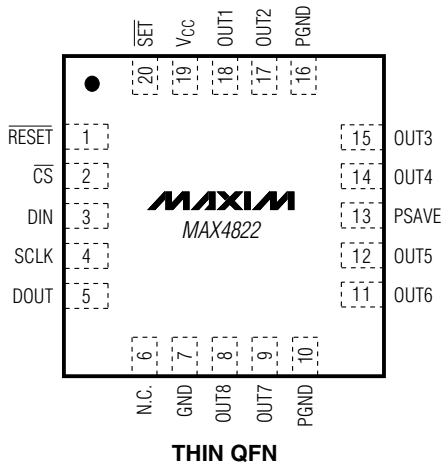

+3.3V/+5V, 8-Channel Relay Drivers with Fast Recovery Time and Power-Save Mode

Package Information

(The package drawing(s) in this data sheet may not reflect the most current specifications. For the latest package outline information, go to www.maxim-ic.com/packages.)

MAX4822-MAX4825

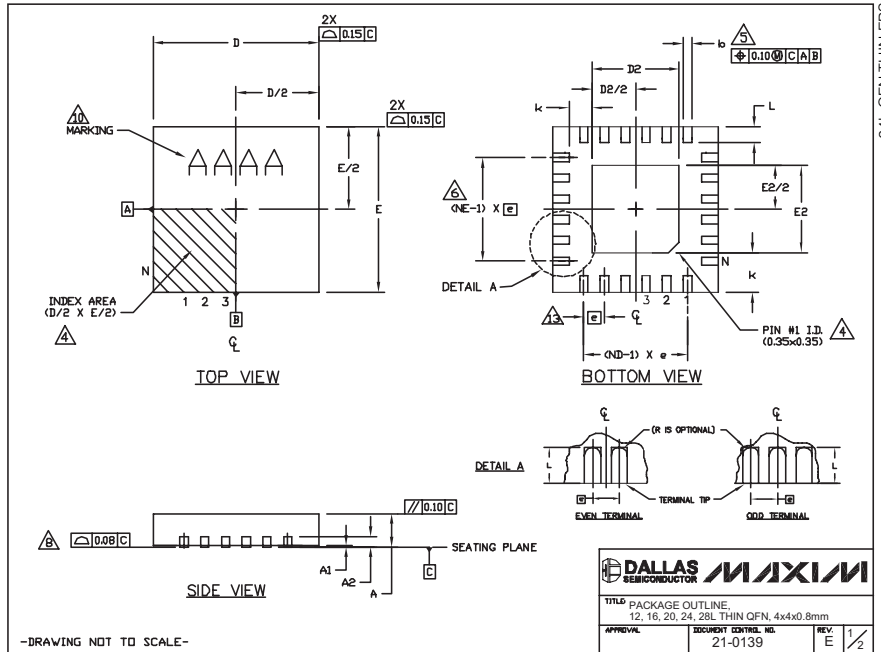

-DRAWING NOT TO SCALE-

PKG REF.	12L 4x4					16L 4x4					20L 4x4					24L 4x4					28L 4x4				
	MIN.	NOM.	MAX.	MIN.	NOM.	MAX.	MIN.	NOM.	MAX.	MIN.	NOM.	MAX.	MIN.	NOM.	MAX.	MIN.	NOM.	MAX.	MIN.	NOM.	MAX.	MIN.	NOM.	MAX.	
A	0.70	0.75	0.80	0.70	0.75	0.80	0.70	0.75	0.80	0.70	0.75	0.80	0.70	0.75	0.80	0.70	0.75	0.80	0.70	0.75	0.80	0.70	0.75	0.80	
A1	0.0	0.02	0.05	0.0	0.02	0.05	0.0	0.02	0.05	0.0	0.02	0.05	0.0	0.02	0.05	0.0	0.02	0.05	0.0	0.02	0.05	0.0	0.02	0.05	
A2	0.20 REF					0.20 REF					0.20 REF					0.20 REF					0.20 REF				
b	0.25	0.30	0.35	0.25	0.30	0.35	0.20	0.25	0.30	0.18	0.23	0.30	0.15	0.20	0.25										
D	3.90	4.00	4.10	3.90	4.00	4.10	3.90	4.00	4.10	3.90	4.00	4.10	3.90	4.00	4.10	3.90	4.00	4.10	3.90	4.00	4.10	3.90	4.00	4.10	
E	3.90	4.00	4.10	3.90	4.00	4.10	3.90	4.00	4.10	3.90	4.00	4.10	3.90	4.00	4.10	3.90	4.00	4.10	3.90	4.00	4.10	3.90	4.00	4.10	
e	0.80 BSC					0.65 BSC					0.50 BSC					0.30 BSC					0.40 BSC				
k	0.25	-	-	0.25	-	-	0.25	-	-	0.25	-	-	0.25	-	-	0.25	-	-	0.25	-	-	0.25	-	-	
L	0.45	0.55	0.65	0.45	0.55	0.65	0.45	0.55	0.65	0.30	0.40	0.50	0.30	0.40	0.50	0.30	0.40	0.50	0.30	0.40	0.50	0.30	0.40	0.50	
N	12			16			20			24			28												
ND	3			4			5			6			7												
NE	3			4			5			6			7												
12345678	VGG8					VGGC					VGGD-1					VGGD-2					VGGE				

PKG CODES	D2			E2			DOWN RINGS ALLOWED
	MIN.	NOM.	MAX.	MIN.	NOM.	MAX.	
T1244-3	1.95	2.10	2.25	1.95	2.10	2.25	YES
T1244-4	1.95	2.10	2.25	1.95	2.10	2.25	NO
T1644-3	1.95	2.10	2.25	1.95	2.10	2.25	YES
T1644-4	1.95	2.10	2.25	1.95	2.10	2.25	NO
T2044-2	1.95	2.10	2.25	1.95	2.10	2.25	YES
T2044-3	1.95	2.10	2.25	1.95	2.10	2.25	NO
T2444-2	1.95	2.10	2.25	1.95	2.10	2.25	YES
T2444-3	2.45	2.60	2.63	2.45	2.60	2.63	YES
T2444-4	2.45	2.60	2.63	2.45	2.60	2.63	NO
T2844-1	2.50	2.60	2.70	2.50	2.60	2.70	NO

NOTES:

- DIMENSIONING & TOLERANCING CONFORM TO ASME Y14.5M-1994.
- ALL DIMENSIONS ARE IN MILLIMETERS. ANGLES ARE IN DEGREES.
- N IS THE TOTAL NUMBER OF TERMINALS.
- THE TERMINAL #1 IDENTIFIER AND TERMINAL NUMBERING CONVENTION SHALL CONFORM TO JEDEC S-1, SPP-012. DETAILS OF TERMINAL #1 IDENTIFIER ARE OPTIONAL, BUT MUST BE LOCATED WITHIN THE ZONE INDICATED. THE TERMINAL #1 IDENTIFIER MAY BE EITHER A MOLD OR MARKED FEATURE.
- DIMENSION b APPLIES TO METALLIZED TERMINAL AND IS MEASURED BETWEEN 0.25 mm AND 0.30 mm FROM TERMINAL TIP.
- ND AND NE REFER TO THE NUMBER OF TERMINALS ON EACH D AND E SIDE RESPECTIVELY.
- DEPOPULATION IS POSSIBLE IN A SYMMETRICAL FASHION.
- COPLANARITY APPLIES TO THE EXPOSED HEAT SINK SLUG AS WELL AS THE TERMINALS.
- DRAWING CONFORMS TO JEDEC M0220, EXCEPT FOR T2444-3, T2444-4 AND T2844-1.
- MARKING IS FOR PACKAGE ORIENTATION REFERENCE ONLY.
- COPLANARITY SHALL NOT EXCEED 0.08mm
- WARPAGE SHALL NOT EXCEED 0.10mm
- LEAD CENTERLINES TO BE AT TRUE POSITION AS DEFINED BY BASIC DIMENSION "e", ±0.05.
- NUMBER OF LEADS SHOWN ARE FOR REFERENCE ONLY.

-DRAWING NOT TO SCALE-

Maxim cannot assume responsibility for use of any circuitry other than circuitry entirely embodied in a Maxim product. No circuit patent licenses are implied. Maxim reserves the right to change the circuitry and specifications without notice at any time.

Maxim Integrated Products, 120 San Gabriel Drive, Sunnyvale, CA 94086 408-737-7600 19